

Datasheet

smartPREDICT-AE RS485/USB

Digital vibration and motion sensor system for IIoT

iNDTact GmbH
 Friedrich-Bergius-Ring 15
 97076 Würzburg
 Germany

+49 (0) 931 2999 7330
 info@indtact.de
 www.indtact.de



Description

The smartPREDICT-AE is a multi-sensor system based on iNDTact's high-bandwidth vibration sensor iMPactXS that enables highly sensitive vibration-based condition monitoring of structures, products and processes. Alongside the high-bandwidth, high-sensitivity vibration sensor, a micro-electromechanical system (MEMS) offers additional motion information (acceleration and angular velocity). The temperature sensor on the bottom of smartPREDICT-AE allows for internal reference temperature measurement next to the iMPactXS.

The smartPREDICT-AE can be used for direct parameter measurement and transmission to machines (PLCs) or edge devices for IIoT via Modbus RTU.

Key Features

- Integrated ultra-low noise acoustic emission sensor with 96 kHz sampling rate
- Integrated acceleration sensor
- Integrated gyroscope sensor
- Integrated temperature sensor
- Autonomous condition monitor with teachable fingerprinting and alarm output
- Output of 11 vibration features (sPR, RMS, etc.) for each Sensors (AE/Acc/Gyro)
- Configurable digital IIR filters for bandwidth and POI control
- Real time raw data streaming*
- Recorder for Raw Data and Spectrum
- GPIOs for digital/analog input or output
- Serial Modbus RTU interface with switchable line termination
- USB interface*
- Firmware updates via bootloader for new features or custom analysis
- IP67 protection

* Available with future Firmware Update

Applications (examples)

- Conditional monitoring of machines & processes with direct input for PLC
- Monitoring and trending of vibrational parameters of high value assets
- Shock and vibration monitoring for construction machine/vehicle or agricultural machine/vehicle
- Materials research
- Production control
- Final inspection and testing
- Incoming goods department
- Biological studies
- Structure monitoring

Properties

Sensors

Type	Sensor	Range	Accuracy	Noise	Sampling Rate	Resolution
Vibration	iMPactXS	0.06 Hz to 48 kHz ±0.15 nC ±1.5 nC ±15 nC		< -99 dB	96 kHz	24 Bit
Acceleration	BMI160	DC to 800 Hz ±2 g ±4 g ±8 g ±16 g	±40 mg	180 µg/√Hz	1.6 kHz	16 Bit
Gyroscope	BMI160	DC to 800 Hz ±125 °/s ±250 °/s ±500 °/s ±1000 °/s ±2000 °/s	±3 °/s	0.007 °/s/√Hz	1.6 kHz	16 Bit
Temperature	LMT01LPG	-40 to 90 °C	±0.5 °C		10 Hz	16 Bit

Components

Component	Details
CPU	ARM Cortex M7
Flash Memory	34 MByte
RAM	32.5 MByte
Connector Interface	M12, 8-pin, x-coded

GPIO Functions

Function	Details
Digital Input/Output	Alert output from Autonomous Condition Monitoring General State and Control Interface*
Analog Input/Output*	Analog-to-Digital converter / Digital-to-Analog-Converter*
Timer Input/Output*	E. g. PWM Input/Output, rotational speed input, ...*
Interrupt Input*	External Interrupt pin for custom functionality*
System Wakeup*	Exit CPU from standby mode*
CAN Interface*	Additional CAN Interface to connect external device / bus*
I2C Interface*	Additional I2C Interface to connect external device / bus*
UART Interface*	Additional UART Interface to connect external device*

* Available with future Firmware Update

Electrical Properties

Parameter	Min	Typical	Max	Unit
Supply Voltage	4.5	5	5.5	V
Supply Current	170		300	mA
GPIO Digital Input Voltage			5	V
GPIO Digital Output Voltage			3.3	V
GPIO Analog Input/Output Voltage			3.3	V
GPIO Internal Series Resistance		1		kΩ
GPIO Pullup/Pulldown Resistance	30	40	50	kΩ
RS485 Operational Common-Mode Range	-25		25	V
RS485 Differential Input Voltage	-25		25	V
RS485 High Level Input Voltage	2			V
RS485 Low Level Input Voltage			0.8	V
RS485 Unit Load			1/8	
RS485 Bus Loads			256	
RS485 Switchable Line Termination		120		Ω

Environmental & Physical Properties

Parameter	Value	Unit
Operating Temperature	-40 to 85	°C
Storage Temperature	-40 to 85	°C
Electromagnetic Compatibility (EMC)	Tested according to DIN EN 61326-1 & 61326-2-3 <ul style="list-style-type: none"> • DIN EN 55011 • DIN EN 61000-4-2 • DIN EN 61000-4-3 • DIN EN 61000-4-4 • DIN EN 61000-4-5 • DIN EN 61000-4-6 • DIN EN 61000-4-8 	
Ingress Protection	IP67	
Dimensions	50 x 89 x 22	mm
Dimension with Mounting Frame	76 x 104 x 22	mm
Weight	98 (+ 18 Mounting Frame)	g
Case Material	Plastic	
Mounting	Adhesive (+ Screw optional)	

Available Options

Option	Specification	Part Number
MC	Standard, C-Prototype	smartPREDICT-AE RS485/USB MC 0 x

Block Diagram

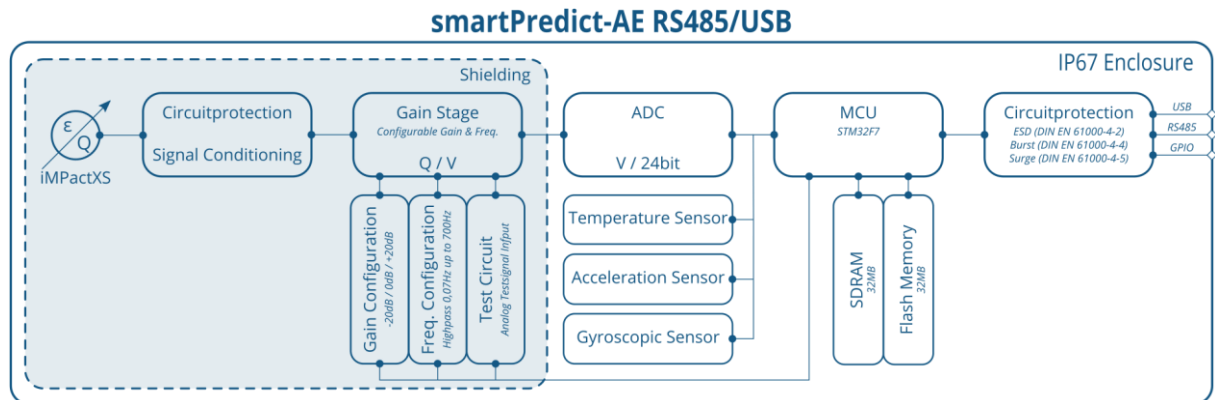

Programmable Gain Stage

The smartPREDICT-AE includes a programmable gain stage for the vibration sensor iMPactXS. Therefore it is possible to adjust the vibration sensor signal in gain and bandwidth for a large variety of applications to obtain an optimal signal to noise ratio. This makes it possible to obtain the desired application information with optimum quality and accuracy and to make precise conclusions about the condition of the machine to be monitored.

The following table gives an overview over the available settings. It is possible to adjust the lower cut off frequency (FREQ) and the transfer gain (GAIN) separately.

	FREQ	LOW	MED	HIGH
GAIN				
LOW (-20 dB)		0.07 Hz	0.7 Hz	7 Hz
MED (0 dB)		0.7 Hz	7 Hz	70 Hz
HIGH (20 dB)		7 Hz	70 Hz	700 Hz
MAX (~40 dB)*		~70 Hz	~700 Hz	~7000 Hz

*The gain "Max" setting may be used but the gain nor the related cut-off frequency are guaranteed. Measurements from different devices are expected to have a high spread using this setting.

Typical Performance Characteristics

Sensor iMPactXS – Gain Setting „High“

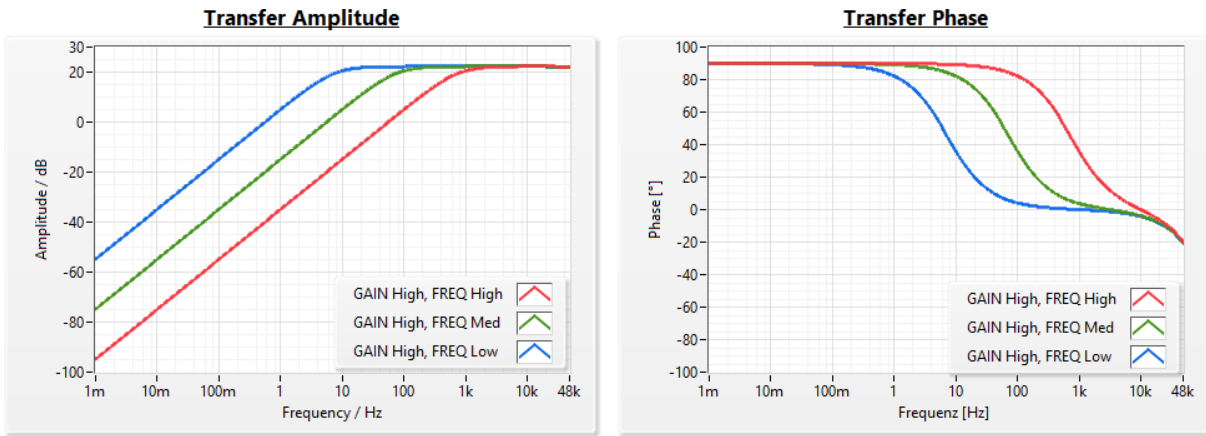

Sensor iMPactXS – Gain Setting „Med“

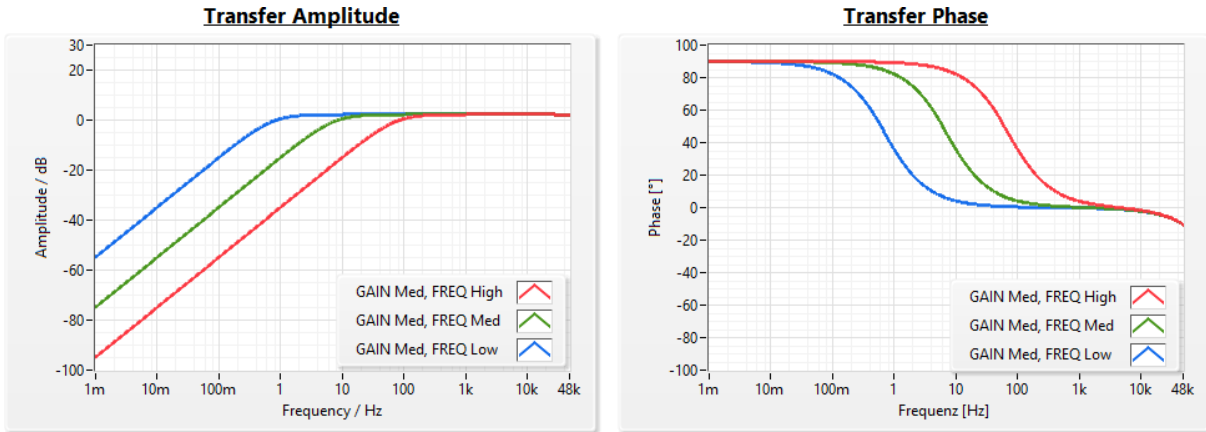

Sensor iMPactXS – Gain Setting „Low“

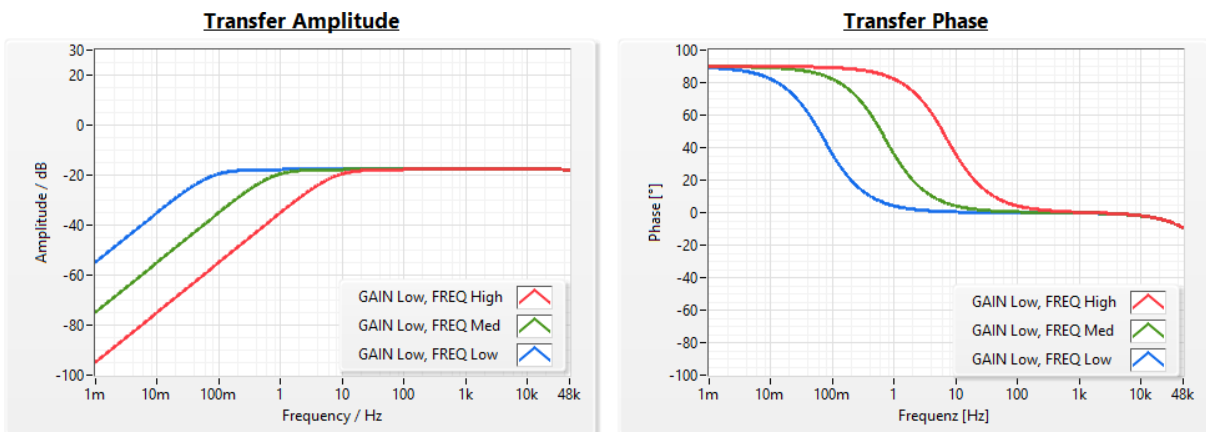

Connector

Pin Allocation on Device (M12, 8-Pin, X-Coded, Female)

Seen from outside onto the device.

- 1. USB D+
- 2. USB D-
- 3. GPIO 1
- 4. GPIO 2
- 5. VDD
- 6. GND
- 7. RS485 A
- 8. RS485 B

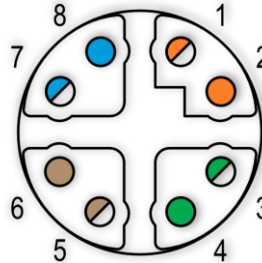

Pin Description

Pin Number	Name	Description
1	USB D+	Non-Inverting Data Line of USB Interface
2	USB D-	Inverting Data Line of USB Interface
3	GPIO 1	Programmable General-Purpose Input/Output for Analog and Digital Signals
4	GPIO 2	Programmable General-Purpose Input/Output for Analog and Digital Signals
5	VDD	Power Supply
6	GND	Ground
7	RS485 A	Inverting Data Line of RS485 Interface*
8	RS485 B	Non-Inverting Data Line of RS485 Interface*

* Incorrect according to Modbus Specification but used by most differential transceiver manufacturers.

Example: Connection via Standard Modbus Cable Setup

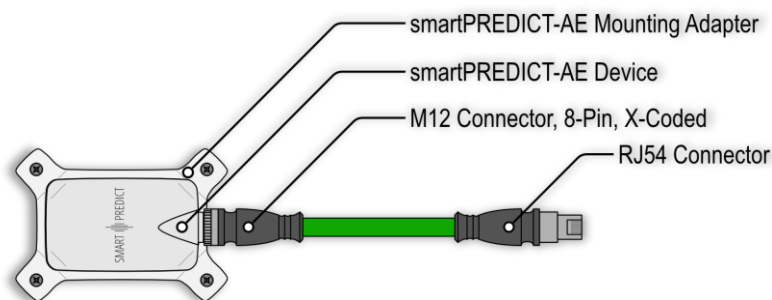

Pin Allocation of Standard Modbus Cable (M12 Male to RJ45 Male)

Plugs seen from front of connector.

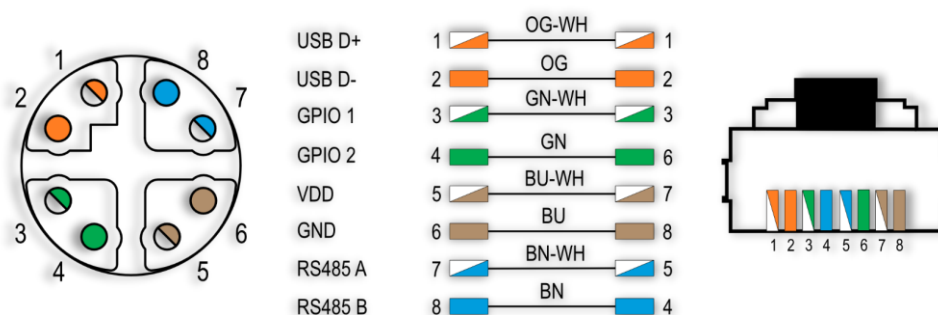

Technical Drawings

Dimensions without Mounting Frame

All dimensions in millimeters.

- View without mounting frame
- If used without mounting frame, adhesive is required for coupling to surface

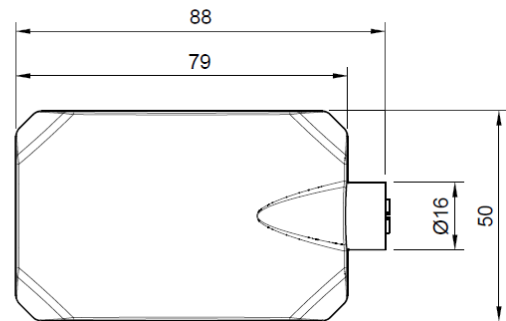
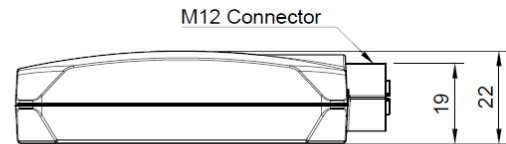
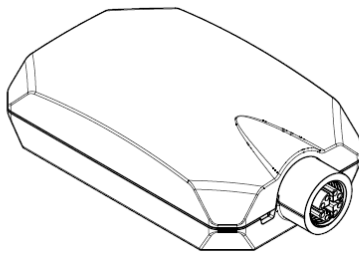

Dimensions with Mounting Frame

- View with mounting frame
- Mounting frame with 4x Ø 6.6 mm holes
- Coupling with adhesive/adhesive tape possible

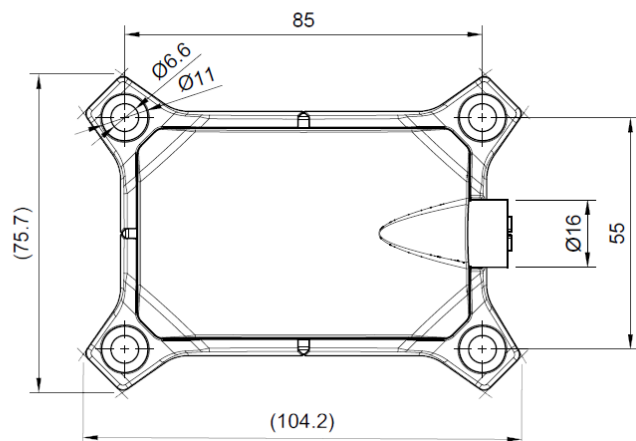
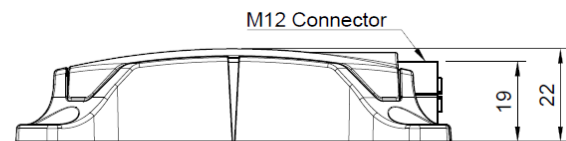
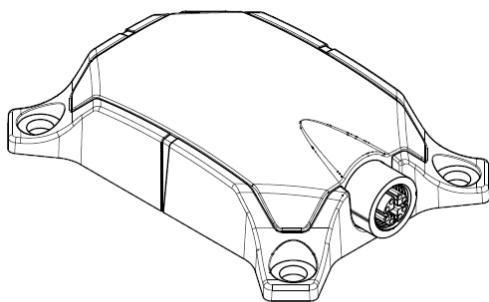

Sensor Positions & Orientation

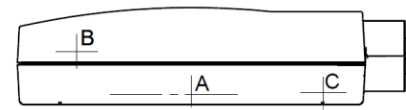
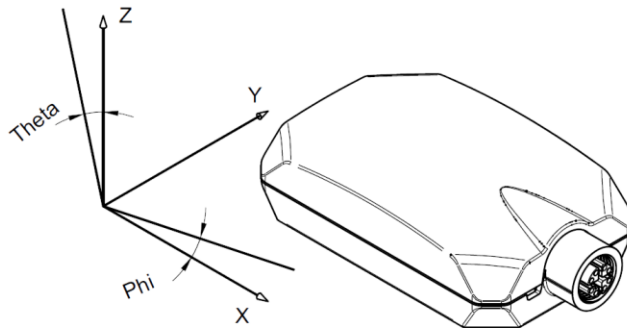

A = AE-Sensor
 B = Acc. & Gyro. Sensor
 C = Temperature Sensor

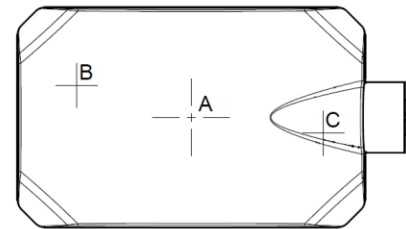

Interface Description

Modbus is a serial communications protocol for industrial electronic devices. It enables communication among many devices connected to the same network. The basic architecture is based on a single master device and up to 247 slave devices. Many hardware interfaces and software libraries provide APIs for Modbus communication.

FURTHER INFORMATION:

See Application Note: "smartPREDICT-AE RS485USB Modbus Reference Guide" for detailed configuration instructions of the Modbus communication. Datasheets, User Guides and Application Notes are available on our website www.indtact.de.

Accessories

- Cable (optional): CAT 7+, 8-pin, x-coded
- Mounting frame: See technical drawings
- Screws for mounting frame (not included in delivery): see technical drawings, max. Ø6 mm
- Glue for coupling of sensor system (not included in delivery): contact iNDTact specialists for consultation

Application Information

For reversible sensor application with low accuracy (e. g. for a quick test) at room temperature, the use of hot-melt adhesive or double-sided tape is possible. An effective quick test coupling is achieved when a drop of hot-melt (e. g. via hot-melt gun) is applied onto the sensor and immediately pressed onto the surface of the test object until solidification. Test objects with high heat capacity must be warmed up in advance to approximately 50°C before hot melt glue is applied to avoid a release due to shrinkage mismatch.

WARNING: During the manual application, the use of an insulation layer or thermo gloves is recommended for protection against heat-injuries.

For reversible sensor application with high accuracy (e. g. proof of concept), the use of a special cement glue is recommended (available upon request).

For permanent sensor application with a higher accuracy and a higher temperature performance, the use of approved structural adhesives with appropriate surface pre-treatment is recommended. iNDTact offers such adhesives for common applications on request.

In general, the surfaces of the test specimen and the sensor bottom side must be free of dust, grease and dirt. In case of contamination, a cleaning with solvent like alcohol, isopropanol or acetone might be necessary. For more information, please contact your structural adhesive supplier.

IMPORTANT: Prior to any applications, especially those relevant to security, the adhesive performance in combination with the sensor must be tested and approved according to the requirements of the use case.

Declaration of Conformity

- CE compliant
- RoHS compliant
- 3TG compliant
- REACH compliant

The smartPREDICT-AE is a component, which contains lead zirconium titanate in a proportion of more than 0.1% by weight.

Lead zirconium titanate (abbreviation: PZT, Lead titanium zirconium oxide) has been included in the SVHC list by the European Chemicals Agency (ECHA) (EC No: 235-727-4, CAS No: 12626-81-2).

iNDTact GmbH does not manufacture PZT itself but purchases it in crystalline and insoluble form from suppliers who have registered the substance with the ECHA. If the device is used as intended, no release of PZT can occur at any time. Risks can only occur in the case of inhalation or oral uptake (e.g. in the form of dust after mechanical processing or machining), but these can be ruled out if used as intended.

Legal Disclaimer

Pre-Series Versions (engineering samples)

Herein described is a pre-series version of the smartPREDICT-AE product. These versions are seen as engineering samples and may vary from the valid technical specifications of the product series contained in this data sheet. They are therefore not intended or fit for resale to third parties or for use in end products. Their sole purpose is internal client testing. The testing of an engineering sample may in no way replace the testing of a product series. iNDTact assumes no liability for the use of samples. The purchaser shall indemnify iNDTact from all claims arising from the use of pre-series versions.

Product Use

iNDTact products may only be used within the parameters of this product data sheet. They are not fit for use in life- sustaining or security sensitive systems. Security sensitive systems are those for which a malfunction is expected to lead to bodily harm or significant property damage. The resale and / or use of products are at the purchaser's own risk and his own responsibility. The examination of fitness for the intended use is the sole responsibility of the purchaser. The purchaser shall indemnify iNDTact from all third party claims arising from any product use not covered by the parameters of this product data sheet or not approved by iNDTact and reimburse iNDTact for all costs in connection with such claims. The purchaser must monitor the market for the purchased products, particularly with regard to product safety, and inform iNDTact without delay of all security relevant incidents.

Application Examples

With respect to any examples given herein, any typical values stated herein and/ or any information regarding the application of the device, iNDTact hereby disclaims any and all warranties and liabilities of any kind, including without limitation warranties of non-infringement of intellectual property rights or copyrights of any third party. The information given in this document shall in no event be regarded as a guarantee of conditions or characteristics. They are provided for illustrative purposes only and no evaluation regarding infringement of intellectual property rights or copyrights or regarding functionality, performance or error has been made.